

OPERATOR'S MANUAL

15 in. DRILL PRESS

DP15501

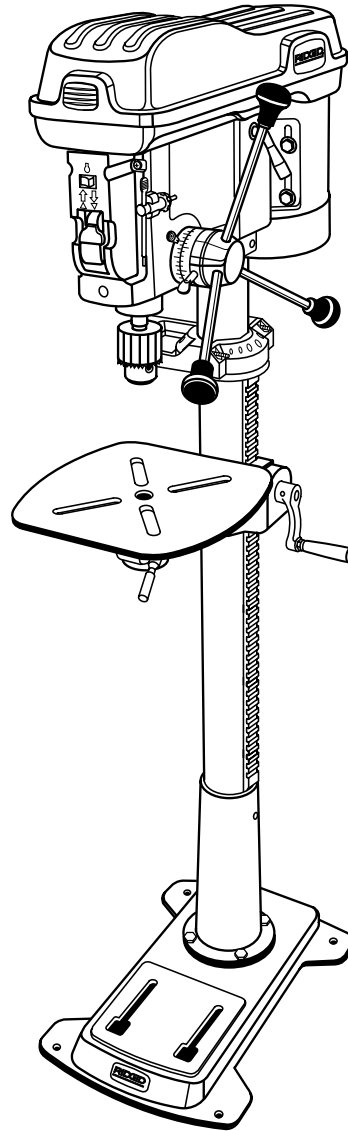

Your new drill press has been engineered and manufactured to our high standards for dependability, ease of operation, and operator safety. When properly cared for, it will give you years of rugged, trouble-free performance.

⚠ WARNING:

To reduce the risk of injury, the user must read and understand the operator's manual before using this product.

Thank you for buying a RIDGID product.

SAVE THIS MANUAL FOR FUTURE REFERENCE

TABLE OF CONTENTS

■ Introduction	2
■ General Safety Rules	3
■ Specific Safety Rules.....	4
■ Symbols.....	5-6
■ Electrical	7
■ Glossary of Terms.....	8
■ Features.....	9-10
■ Unpacking	11
■ Loose Parts.....	12
■ Tools Needed.....	13
■ Assembly	13-17
■ Operation.....	18-21
■ Adjustments.....	22-26
■ Maintenance	27
■ Accessories	28
■ Troubleshooting	29
■ Warranty	31
■ Parts Ordering/Service	32

INTRODUCTION

Your drill press has many features for making the use of this product more pleasant and enjoyable. Safety, performance, and dependability have been given top priority in the design of this product making it easy to maintain and operate.

GENERAL SAFETY RULES



WARNING:

Read and understand all instructions. Failure to follow all instructions listed below, may result in electric shock, fire and/or serious personal injury.

READ ALL INSTRUCTIONS

- **KNOW YOUR POWER TOOL.** Safe operation of this power tool requires that you read and understand this operator's manual and all labels affixed to the tool. Learn its applications and limitations as well as the potential hazards.
- **GUARD AGAINST ELECTRICAL SHOCK** by preventing body contact with grounded surfaces such as pipes, radiators, ranges, refrigerator enclosures.
- **KEEP GUARDS IN PLACE** and in good working order. Never operate the tool with any guard or cover removed. Make sure all guards are operating properly before each use.
- **REMOVE ADJUSTING KEYS AND WRENCHES.** Get in the habit - before turning on tool - that hex keys and adjusting wrenches are removed from tool.
- **KEEP THE WORK AREA CLEAN.** Cluttered work areas and work benches invite accidents. **DO NOT** leave tools or pieces of wood on the machine while it is in operation.
- **DO NOT USE IN DANGEROUS ENVIRONMENTS.** Do not use power tools near gasoline or other flammable liquids, in damp or wet locations, or expose them to rain. Keep the work area well lighted.
- **KEEP CHILDREN AND VISITORS AWAY.** All visitors should wear safety glasses and be kept a safe distance from work area. Do not let visitors contact tool or extension cord while operating.
- **MAKE WORKSHOP CHILDPROOF** with padlocks and master switches or by removing starter keys.
- **DO NOT FORCE THE TOOL** it will do the job better and safer at the rate for which it was designed.
- **USE THE RIGHT TOOL FOR THE JOB.** Do not force the tool or attachment to do a job for which it was not designed for. Use it only the way it was intended.
- **USE THE PROPER EXTENSION CORD.** Make sure your extension cord is in good condition. Use only a cord heavy enough to carry the current your product will draw. An undersized cord will cause a drop in line voltage resulting in loss of power and overheating. A wire gage size (A.W.G.) of at least **14** is recommended for an extension cord **25** feet or less in length. If in doubt, use the next heavier gage. The smaller the gage number, the heavier the cord.
- **DRESS PROPERLY.** Do not wear loose clothing, gloves, neckties, rings, bracelets, or other jewelry that could get caught and draw you into moving parts. Non-slip footwear is recommended. Wear protective covering over long hair.
- **ALWAYS WEAR SAFETY GLASSES WITH SIDE SHIELDS.** Everyday eyeglasses have only impact resistant lenses; they are not safety glasses.
- **PROTECT YOUR LUNGS.** Wear a face or dust mask if the operation is dusty.
- **PROTECT YOUR HEARING.** Wear hearing protection during extended periods of operation.
- **SECURE WORK.** Use clamps or a vise to hold the work when practical. It's safer than using your hand and frees both hands to operate the tool.
- **DO NOT OVERREACH.** Keep proper footing and balance at all times.
- **MAINTAIN TOOLS WITH CARE.** Keep tools sharp and clean for better and safer performance. Follow instructions for lubricating and changing accessories.
- **DISCONNECT ALL TOOLS.** When not in use, before servicing, or when changing attachments, all tools should be disconnected.
- **AVOID ACCIDENTAL STARTING.** Be sure switch is off when plugging in any tool.
- **USE RECOMMENDED ACCESSORIES.** Consult this operator's manual for recommended accessories. The use of improper accessories may cause risk of injury.
- **NEVER STAND ON TOOL.** Serious injury could occur if the tool is tipped or if the bit is unintentionally contacted.
- **CHECK DAMAGED PARTS.** Before using the tool, a guard or other part that is damaged should be carefully checked to determine that it will operate properly and perform its intended function. Check for alignment of moving parts, binding of moving parts, breakage of parts, mounting and any other conditions that may affect operation. A guard or other part that is damaged must be properly repaired or replaced by an authorized service center to avoid risk of personal injury.
- **NEVER LEAVE TOOL RUNNING UNATTENDED, TURN THE POWER OFF.** Do not leave tool until it comes to a complete stop.
- **DO NOT ABUSE CORD.** Never yank the cord to disconnect it from the receptacle. Keep the cord from heat, oil, and sharp edges.
- **KEEP TOOL DRY, CLEAN, AND FREE FROM OIL AND GREASE.** Always use a clean cloth when cleaning. Never use brake fluids, gasoline, petroleum-based products, or any solvents to clean tool.
- **STAY ALERT AND EXERCISE CONTROL.** Watch what you are doing and use common sense. Do not operate tool when you are tired. Do not rush.
- **DO NOT USE TOOL IF SWITCH DOES NOT TURN IT ON AND OFF.** Have defective switches replaced by an authorized service center.
- **ALWAYS TURN SWITCH OFF** before disconnecting it to avoid accidental starting.

SPECIFIC SAFETY RULES

- **KEEP BITS CLEAN AND SHARP.** Sharp bits minimize stalling. Dirty and dull bits may cause misalignment of the material and possible operator injury.
- **KEEP HANDS AWAY FROM WORK AREA.** Keep hands away from the bit. Restrain any loose clothing, jewelry, long hair, etc. that may become entangled in the bit.
- **DO NOT** wear gloves, necktie, or loose clothing.
- **ALWAYS CLAMP WORKPIECE AND BRACE AGAINST COLUMN TO PREVENT ROTATION.** Never use your hand to hold the object while drilling.
- **USE RECOMMENDED SPEED FOR DRILL ACCESSORY AND WORKPIECE MATERIAL.**
- **BE SURE DRILL BIT OR CUTTING TOOL IS SECURELY LOCKED IN THE CHUCK.**
- **BE SURE CHUCK KEY IS REMOVED** from the chuck before connecting to power source or turning power **ON**.
- **ADJUST THE TABLE OR DEPTH STOP TO AVOID DRILLING INTO THE TABLE.** Shut off the power, remove the drill bit, and clean the table before leaving machine.
- **DO NOT CONNECT TOOL TO POWER SOURCE OR OPERATE UNTIL IT IS COMPLETELY ASSEMBLED AND INSTALLED ACCORDING TO THE INSTRUCTIONS.** If any part of your drill press malfunctions or has been damaged or broken, do not operate until the part is properly repaired or replaced.
- **NEVER PLACE YOUR FINGERS IN A POSITION WHERE THEY COULD CONTACT THE DRILL** or other cutting tool if the workpiece should unexpectedly shift.
- **NEVER PERFORM ANY OPERATION** by moving the head or table with respect to one another. Do not turn the motor switch **ON** or start any operation before checking that the head and table support lock handle is clamped tight to column and head and table support collars are correctly positioned.
- **BEFORE ENGAGING THE POWER SWITCH ON, MAKE SURE THE BELT GUARD IS DOWN AND THE CHUCK IS INSTALLED PROPERLY.**
- **LOCK THE MOTOR SWITCH OFF WHEN LEAVING THE DRILL PRESS.** Do not perform layout, assembly, or set-up work on the table while the cutting tool is rotating, switched on or connected to a power source.
- **SAVE THESE INSTRUCTIONS.** Refer to them frequently and use to instruct other users. If you loan someone this tool, loan them these instructions also.

WARNING:









Some dust created by power sanding, sawing, grinding, drilling, and other construction activities contains chemicals known to cause cancer, birth defects or other reproductive harm. Some examples of these chemicals are:

- lead from lead-based paints,
- crystalline silica from bricks and cement and other masonry products, and
- arsenic and chromium from chemically-treated lumber.

Your risk from these exposures varies, depending on how often you do this type of work. To reduce your exposure to these chemicals: work in a well ventilated area, and work with approved safety equipment, such as those dust masks that are specially designed to filter out microscopic particles.



SYMBOLS

Some of the following symbols may be used on this tool. Please study them and learn their meaning. Proper interpretation of these symbols will allow you to operate the tool better and safer.

SYMBOL	NAME	DESIGNATION/EXPLANATION
V	Volts	Voltage
A	Amperes	Current
Hz	Hertz	Frequency (cycles per second)
W	Watt	Power
min	Minutes	Time
~	Alternating Current	Type of current
==	Direct Current	Type or a characteristic of current
n_0	No Load Speed	Rotational speed, at no load
	Class II Construction	Double-insulated construction
.../min	Per Minute	Revolutions, strokes, surface speed, orbits etc., per minute
	Wet Conditions Alert	Do not expose to rain or use in damp locations.
	Read The Operator's Manual	To reduce the risk of injury, user must read and understand operator's manual before using this product.
	Eye Protection	Always wear safety goggles or safety glasses with side shields and a full face shield when operating this product.
	Safety Alert	Precautions that involve your safety.
	No Hands Symbol	Failure to keep your hands away from the blade will result in serious personal injury.
	No Hands Symbol	Failure to keep your hands away from the blade will result in serious personal injury.
	No Hands Symbol	Failure to keep your hands away from the blade will result in serious personal injury.
	No Hands Symbol	Failure to keep your hands away from the blade will result in serious personal injury.

SYMBOLS

The following signal words and meanings are intended to explain the levels of risk associated with this product.

SYMBOL	SIGNAL	MEANING
	DANGER:	Indicates an imminently hazardous situation, which, if not avoided, will result in death or serious injury.
	WARNING:	Indicates a potentially hazardous situation, which, if not avoided, could result in death or serious injury.
	CAUTION:	Indicates a potentially hazardous situation, which, if not avoided, may result in minor or moderate injury.
	CAUTION:	(Without Safety Alert Symbol) Indicates a situation that may result in property damage.

SERVICE

Servicing requires extreme care and knowledge and should be performed only by a qualified service technician. For service we suggest you return the product to your nearest **AUTHORIZED SERVICE CENTER** for repair. When servicing, use only identical replacement parts.



WARNING:

To avoid serious personal injury, do not attempt to use this product until you read thoroughly and understand completely the operator's manual. Save this operator's manual and review frequently for continuing safe operation and instructing others who may use this product.

WARNING:



The operation of any tool can result in foreign objects being thrown into your eyes, which can result in severe eye damage. Before beginning operation, always wear safety goggles or safety glasses with side shields and a full face shield when needed. We recommend Wide Vision Safety Mask for use over eyeglasses or standard safety glasses with side shields. Always wear eye protection which is marked to comply with ANSI Z87.1.

SAVE THESE INSTRUCTIONS

ELECTRICAL

EXTENSION CORDS

Use only 3-wire extension cords that have 3-prong grounding plugs and 3-pole receptacles that accept the tool's plug. When using a power tool at a considerable distance from the power source, use an extension cord heavy enough to carry the current that the tool will draw. An undersized extension cord will cause a drop in line voltage, resulting in a loss of power and causing the motor to overheat. Use the chart provided below to determine the minimum wire size required in an extension cord. Only round jacketed cords listed by Underwriter's Laboratories (UL) should be used.

Length of Extension Cord	Wire Size (A.W.G.)
Up to 25 feet	14
26-50 feet	14

When working with the tool outdoors, use an extension cord that is designed for outside use. This is indicated by the letters **WA** on the cord's jacket.

Before using an extension cord, inspect it for loose or exposed wires and cut or worn insulation.

CAUTION:

Keep the cord away from the cutting area and position the cord so that it will not be caught on material, tools, or other objects during cutting.

ELECTRICAL CONNECTION

Your drill press is powered by a precision built electric motor. It should be connected to a **power supply that is 120 volts, 60 Hz, AC only (normal household current)**. Do not operate this tool on direct current (DC). A substantial voltage drop will cause a loss of power and the motor will overheat. If the machine does not operate when plugged into an outlet, double check the power supply.

POWER SUPPLY

Before operating your drill press, check your power supply and make sure it meets the requirements listed on the tool's data plate. A substantial voltage drop will cause a loss of power and machine overheating.

Common causes of power loss and machine overheating are insufficient extension cord size and multiple tools operating from the same power source.

GROUNDING INSTRUCTIONS

In the event of a malfunction or breakdown, grounding provides a path of least resistance for electric current to reduce the risk of electric shock. This tool is equipped with an electric cord having an equipment-grounding conductor and a grounding plug. The plug must be plugged into a matching outlet that is properly installed and grounded in accordance with all local codes and ordinances.

Do not modify the plug provided. If it will not fit the outlet, have the proper outlet installed by a qualified electrician. Improper connection of the equipment-grounding conductor can result in a risk of electric shock. The conductor with insulation having an outer surface that is green with or without yellow stripes is the equipment-grounding conductor. If repair or replacement of the electric cord or plug is necessary, do not connect the equipment-grounding conductor to a live terminal.

Check with a qualified electrician or service personnel if the grounding instructions are not completely understood, or if in doubt as to whether the tool is properly grounded.

Repair or replace a damaged or worn cord immediately.

This tool is intended for use on a circuit that has an outlet like the one shown in Figure 1. It also has a grounding pin like the one shown.

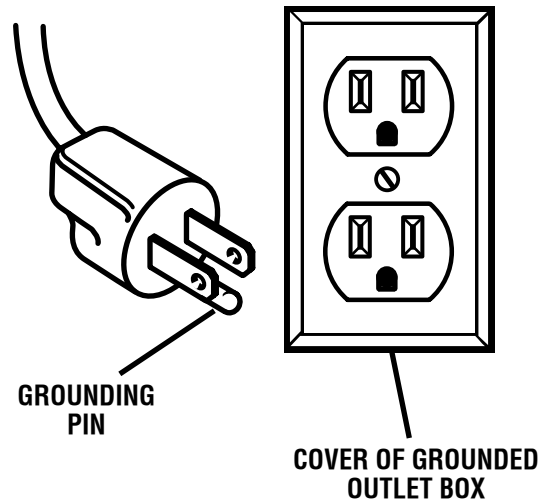

Fig. 1

GLOSSARY OF TERMS

Base

Large rectangular plate that secures the drill press to a benchtop or other sturdy, level surface.

Chip

The material extracted from the hole in a drilling operation.

Chuck

The clamping device at the end of the spindle that secures the drill bit.

Chuck Key

A fitted key used to tighten and loosen the chuck.

Column

Large perpendicular rod that supports the work table and drill press head assembly.

Depth Stop

Adjustment control which allows the operator to control the depth of the hole in a drilling operation.

Drill Bit

Fluted cutting tool used in a drilling operation.

Head Assembly

The assembly at the top of the column which houses the motor, quill, and spindle.

Feed

The speed and force with which the drill bit is lowered into the workpiece.

Feed Handles

Three handles attached to the quill which allow the operator to lower the chuck and bit during a drilling operation.

Motor Pulley

A grooved, conical pulley driven by the motor and responsible for driving the spindle pulley by means of a belt.

Pilot Hole

A small hole drilled in a workpiece that serves as a guide for drilling large holes accurately.

Quill

Also known as the Feed Shaft. Responsible for lowering the chuck and bit into the workpiece and regulating the depth of the hole in a drilling operation.

Spindle

The rotating shaft upon which the chuck is attached.

Spindle Pulley

A grooved, conical pulley responsible for rotating the spindle. The spindle pulley is driven by the motor pulley by means of a belt.

Workpiece

The object into which a hole is to be drilled.

Worktable

Flat, level surface supported on the column and able to be positioned at various angles vertically on the column in order to accommodate different size workpieces.

FEATURES

PRODUCT SPECIFICATIONS

- Input..... 120V, 60 Hz, AC Only, 8 Amperes
- Motor1/2 HP Induction
- No Load Speed..... 300-3100/min.
- Net Weight 158.4 lbs. (72 kg)
- Number of Speeds 12
- Chuck Size.....5/8 in. (1.6 cm)
- Spindle Travel 3-3/4 in. (9.5 cm)
- Overall Height 65-1/2 in. (166.4 cm)

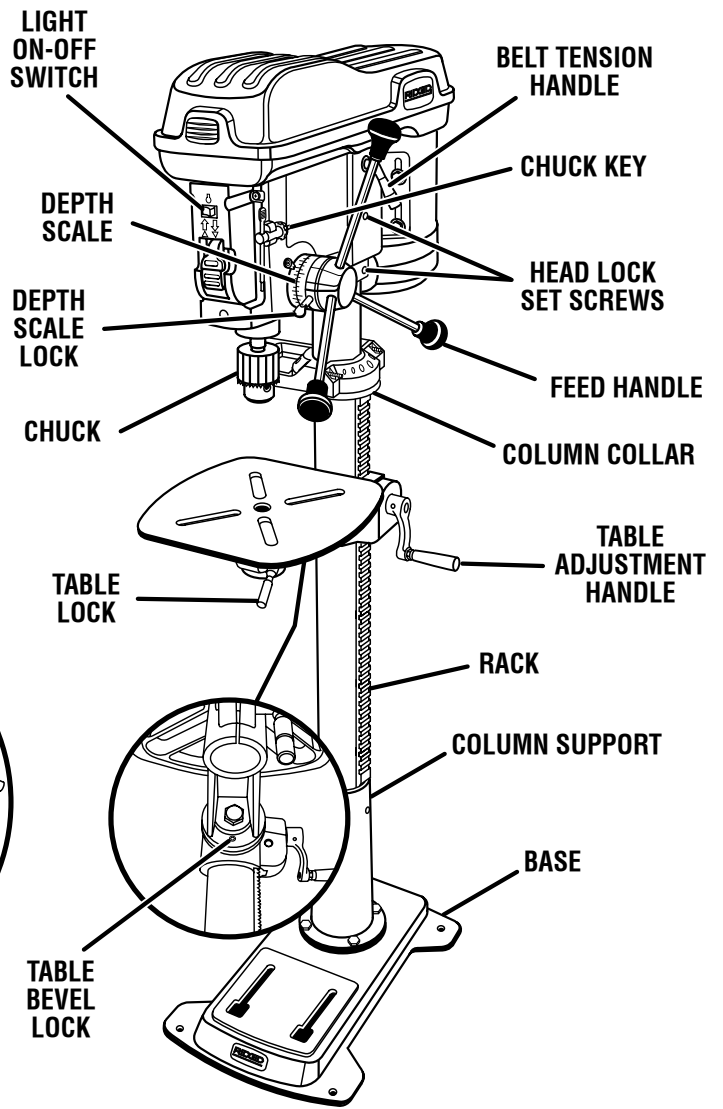
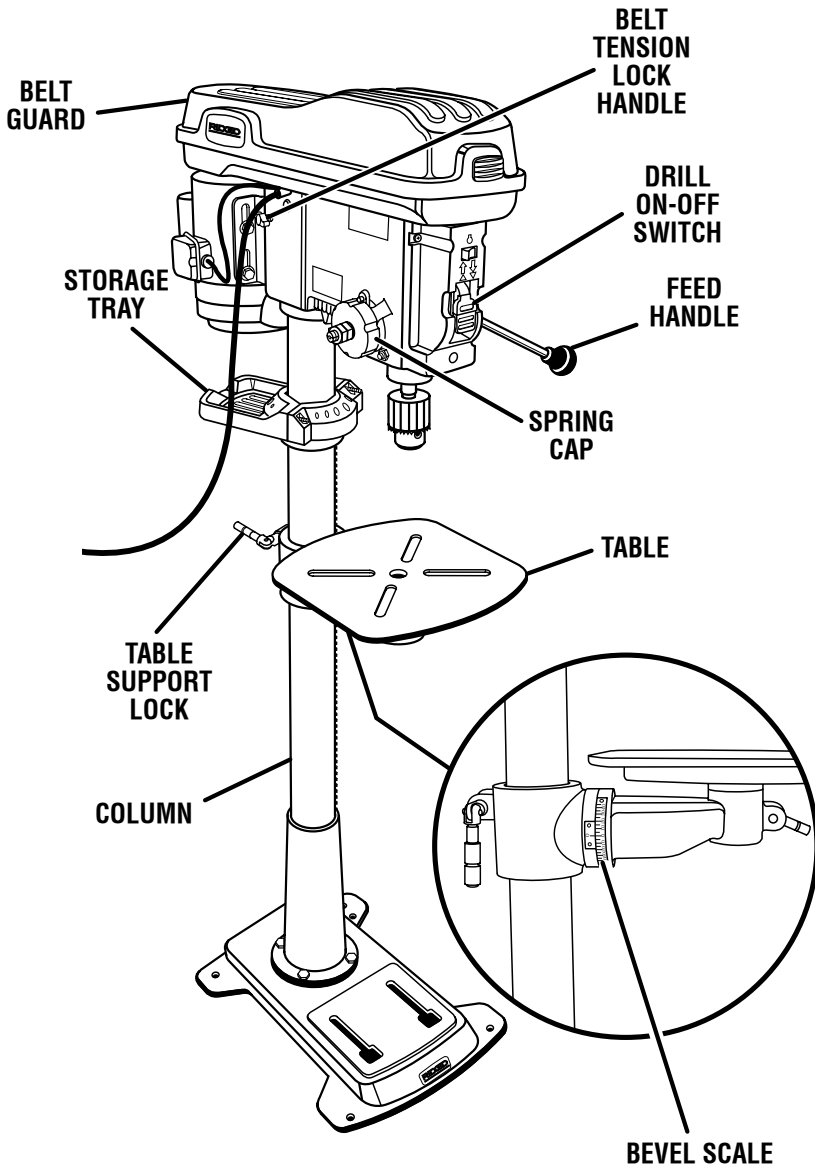

Fig. 2

FEATURES

KNOW YOUR DRILL PRESS

See Figure 2.

Before attempting to use your drill press, familiarize yourself with all operating features and safety requirements.

WARNING:

Do not allow familiarity with your machine to make you careless. Remember that a careless fraction of a second is sufficient to inflict severe injury.

BELT GUARD

Covers pulleys and belt during operation of drill press.

BELT TENSION LOCK HANDLE

Tightening handle locks motor bracket support to maintain correct belt distance and tension.

BELT TENSION HANDLE

Turn handle counterclockwise to apply tension to belt, turn handle clockwise to release belt tension. Refer to section "Assembly- To Install the Idler Pulley and To Tension the Belts".

HEAD LOCK SET SCREWS

Lock the head to the column. Always have them locked in place while operating the drill press.

FEED HANDLE

For moving the chuck up or down. One or two of the handles may be removed if necessary whenever the workpiece is of such unusual shape that it interferes with the handles.

COLUMN COLLAR

Holds the rack to the column. Rack remains movable in collar to permit table support movements.

TABLE ADJUSTMENT HANDLE

Turn clockwise to elevate table. Table support lock must be released before operating crank.

RACK

Combines with gear mechanism to provide easy elevation of table by hand operated table adjustment handle.

BASE

Supports drill press. For additional stability, holes are provided in base to bolt drill press to floor.

COLUMN SUPPORT

Supports column, guides rack, and provides mounting holes for column to base.

TABLE

Provides working surface to support workpiece.

DEPTH SCALE

Shows depth of hole being drilled in inches and millimeters.

DEPTH SCALE LOCK

Locks the depth scale to selected depth.

CHUCK

Holds drill bit or other recommended accessory to perform desired operations.

TABLE BEVEL LOCK

Locks the table in any position from 0°- 45°.

TABLE LOCK

Table can be rotated in various positions and locked.

BEVEL SCALE

Shows degree table is tilted for bevel operations. Scale is mounted on table support. It is to be used for quick reference where accuracy is not critical.

TABLE SUPPORT LOCK

Tightening locks table support to column. Always have it locked in place while operating the drill press.

STORAGE TRAY

Conveniently holds drill bits and other accessories.

ON-OFF SWITCH

Has locking feature. This feature is intended to prevent unauthorized and possible hazardous use by children and others. Insert key into switch.

UNPACKING

The Drill Press is shipped complete in one box.

- Remove the packing materials from around your drill press.
- Separate all loose parts from packing materials and check each item with illustration and “List of Loose Parts.”
- Carefully lift the parts out of carton. This is a heavy drill press. To avoid back injury, get help when needed.
- Do not discard the packing materials until you have carefully inspected the drill press, identified all loose parts, and satisfactorily operated your new drill press.
- Remove the protective oil that is applied to the table and column. Use any ordinary household type grease and spot remover.

- Apply a coat of paste wax to the table and column to prevent rust. Wipe all parts thoroughly with a clean dry cloth.
- Examine all parts to make sure no breakage or damage has occurred during shipping.

If any parts are damaged or missing, do not attempt to plug in the power cord and turn the switch on until the damaged or missing parts are obtained and are installed correctly. Contact your nearest RIDGID dealer or call 1-866-539-1710 for assistance if any parts are missing or damaged.



WARNING:

If any parts are missing do not operate your drill press until the missing parts are replaced. Failure to do so could result in possible serious injury.

LOOSE PARTS

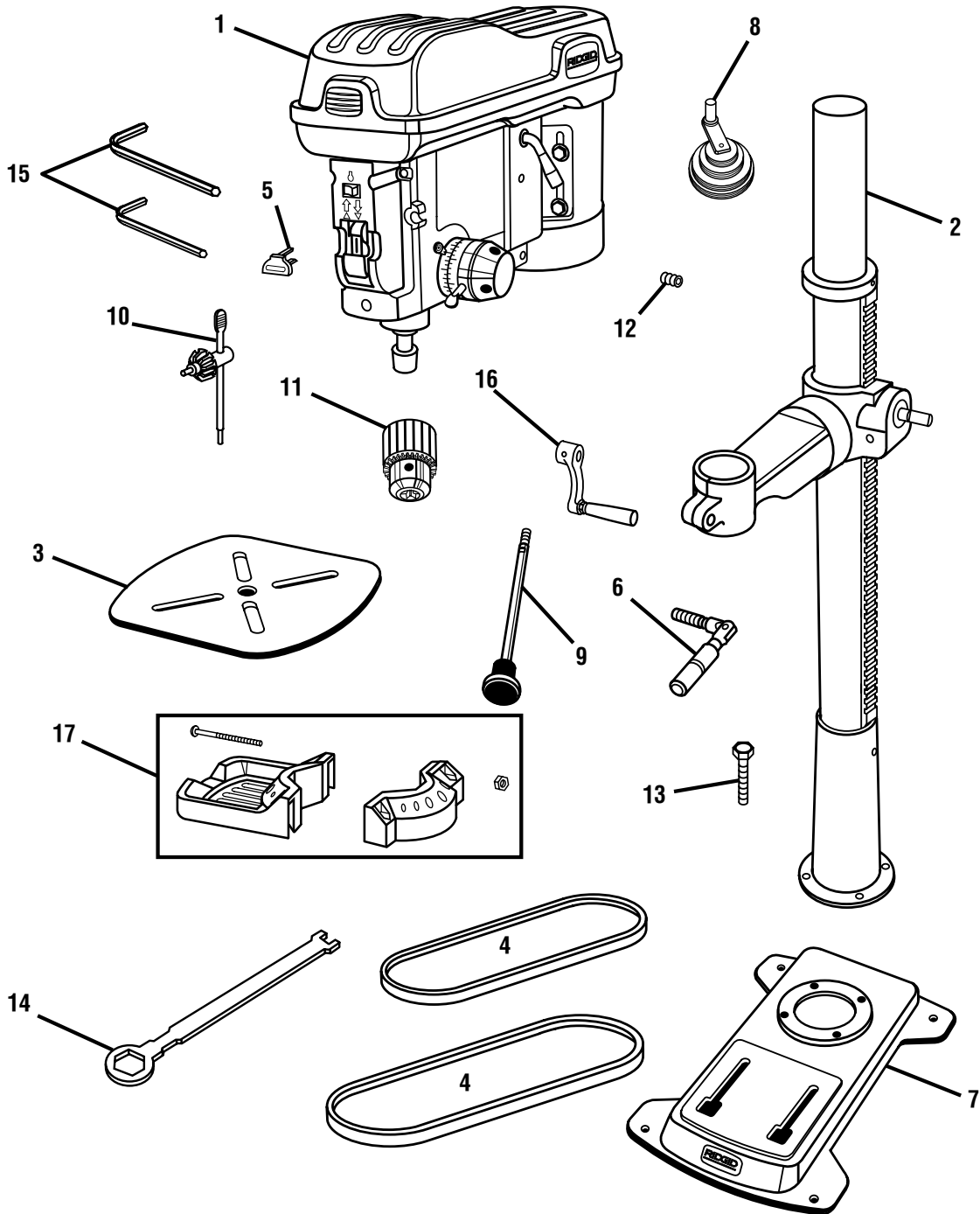
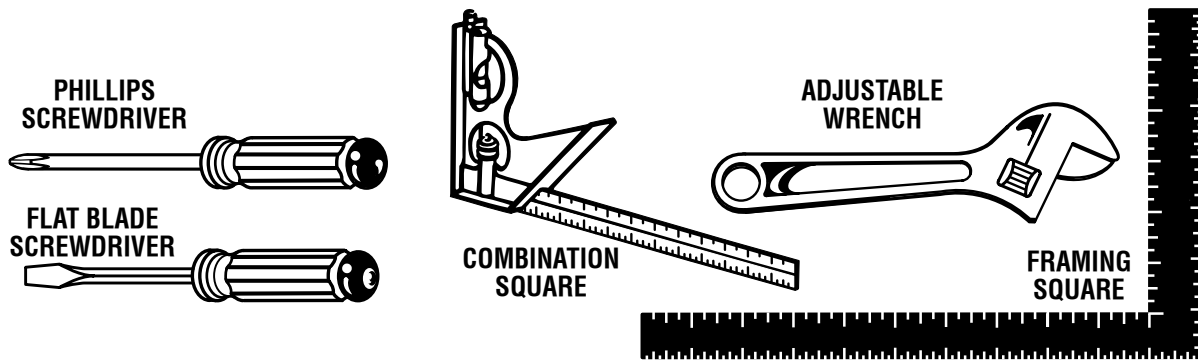

Fig. 3

Key No.	Description	Qty.	Key No.	Description	Qty.
1	Head Assembly.....	1	10	Chuck Key	1
2	Column Assembly.....	1	11	Chuck.....	1
3	Table.....	1	12	Head Lock Set Screws, M10 x 1.5-12.....	2
4	Belts.....	2	13	Hex Bolts, M10 x 1.5-40.....	4
5	Switch Key	1	14	Hex Box Wrench.....	1
6	Table Lock Handle	1	15	Hex Keys.....	2
7	Base.....	1	16	Table Adjustment Handle.....	1
8	Idler Pulley	1	17	Storage Tray.....	1
9	Feed Handles.....	3	18	Operator's Manual (not shown).....	1

TOOLS NEEDED

The following tools (not included) are needed:



ASSEMBLY

⚠ WARNING:

Do not connect to power supply until assembly is complete. Failure to comply could result in accidental starting and possible serious injury.

TO ATTACH THE COLUMN ASSEMBLY TO THE BASE

See Figure 4.

- Locate four hex head bolts.
- Position base on flat surface. Remove protective covering and discard.
- Remove protective sleeve from column tube and discard. Place column assembly on base, and align holes in column support with holes in base.
- Install a hex head bolt in each hole through column support and base and tighten with adjustable wrench.

TO ATTACH THE TABLE CRANK AND TABLE LOCK

See Figure 5.

- Locate table crank and table lock.
- Install table lock from **left side** into table support and tighten by hand.
- Install table crank assembly.
- Tighten set screw with a 3 mm hex key. Do not overtighten.

NOTE: Set screw should be tightened against the flat section of the shaft.

NOTE: To minimize crank backlash, tighten table lock, rotate elevation worm shaft clockwise, then assemble crank tight against table support and tighten set screw.

- Check column collar for proper adjustment. Collar should not be angled on the column and it should be positioned so rack will slide freely in collar when table is rotated 360° around column tube. If readjusted, only tighten set screw enough to keep collar in place.

NOTE: To reduce the risk of column or collar damage, do not overtighten set screw.

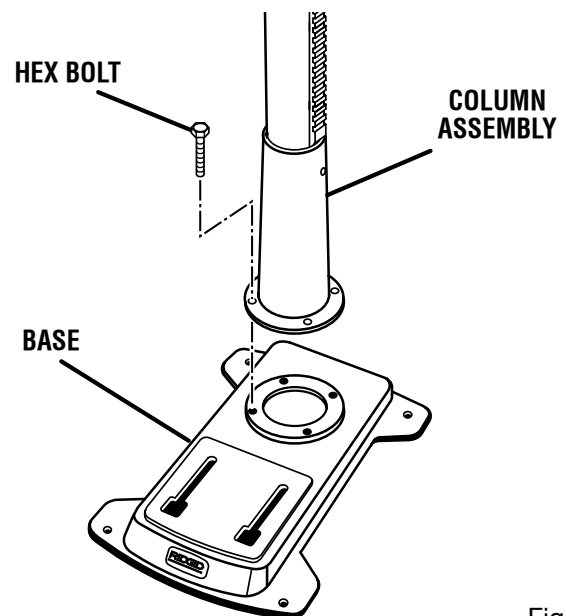

Fig. 4

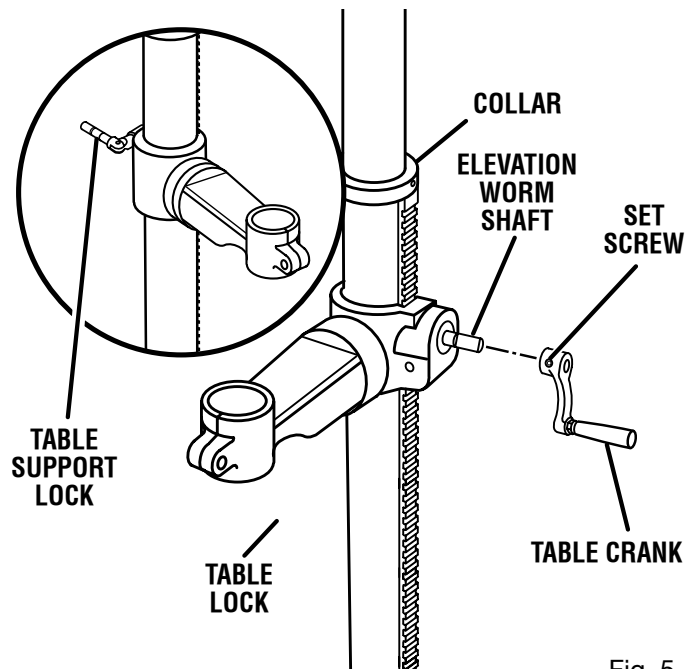

Fig. 5

ASSEMBLY

TO INSTALL THE TABLE

See Figure 6.

- Loosen table support lock and raise table support by turning table crank clockwise until support is at a working height level. Tighten table support lock.
- Remove protective covering from table and discard. Loosen table lock, place table in table support and tighten table lock (located under table) by hand.

NOTE: If table won't fit into table support easily, pry open table support with a flat blade screwdriver.

TO INSTALL THE HEAD ASSEMBLY

See Figure 7.

⚠ CAUTION:

The head assembly weighs approximately 80 pounds (36.4 kg). To reduce the risk of back injury get help to lift the head.

- Locate set screws.
- Remove protective bag from head assembly and discard. Carefully lift head above column tube and slide it onto column making sure head slides down over column as far as possible. Align head with table and base.
- Install a set screw in each hole as indicated on the right side of the head, and using a 5 mm hex key, tighten the two head lock set screws.

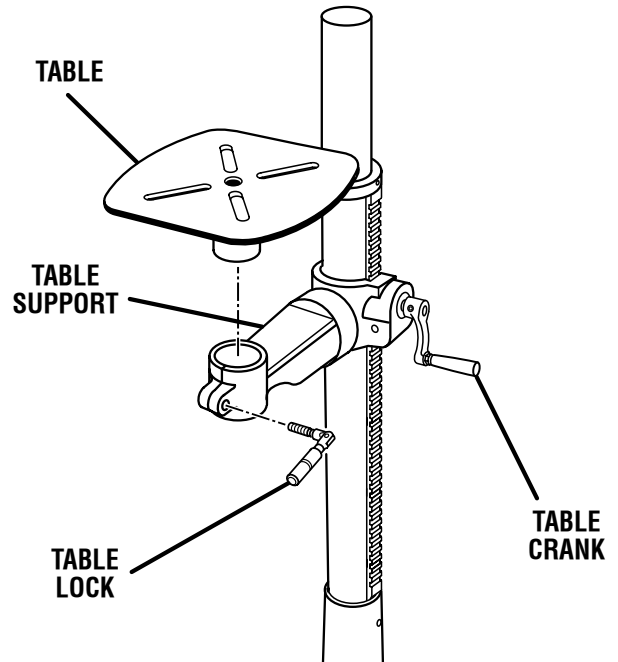

Fig. 6

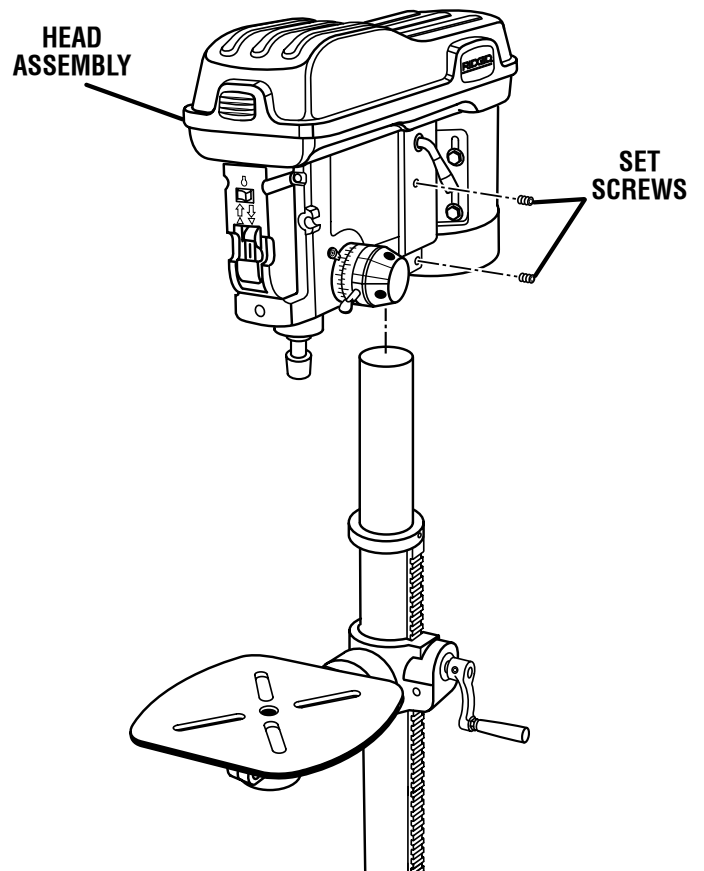

Fig. 7

ASSEMBLY

TO INSTALL THE IDLER PULLEY

See Figure 8.

- Locate the idler pulley and two belts.
- Press the belt guard latch and lift belt guard.
- Place a straightedge such as a piece of wood, metal, or framing square across the top of the spindle pulley and motor pulley.
- The top of the two pulleys should be aligned.
- If pulleys are not aligned:
 - Loosen the motor mount nuts.
 - Move the motor until the pulleys are in line.
 - Retighten the motor mount nuts.

NOTE: To avoid rattles or other noise, motor frame must not touch lower belt guard.

- Place idler pulley in the center hole in the head assembly.

NOTE: The idler pulley should "float" in place.

- Fit one belt (shorter) over the motor pulley and the idler pulley and the other belt (longer) over the spindle pulley and the idler pulley. Tighten the belt tension handle and the two belt tension screws.

NOTE: The longer of the two belts is always positioned between the spindle pulley and idler pulley.

IMPORTANT: Visually check to make sure the four ribs on the belt are placed into the four pulley grooves.

TO TENSION THE BELTS

See Figure 9.

- Apply tension to belt by turning belt tension handle counterclockwise until belt deflects approximately 1/2 in. by thumb pressure at its center.
- Tighten belt tension lock handles.

NOTE: Over tensioning belt may cause motor not to start or damage bearings.

- If belt slips while drilling, readjust belt tension. Also make sure the ribs in the belt are aligned with grooves in the pulley.

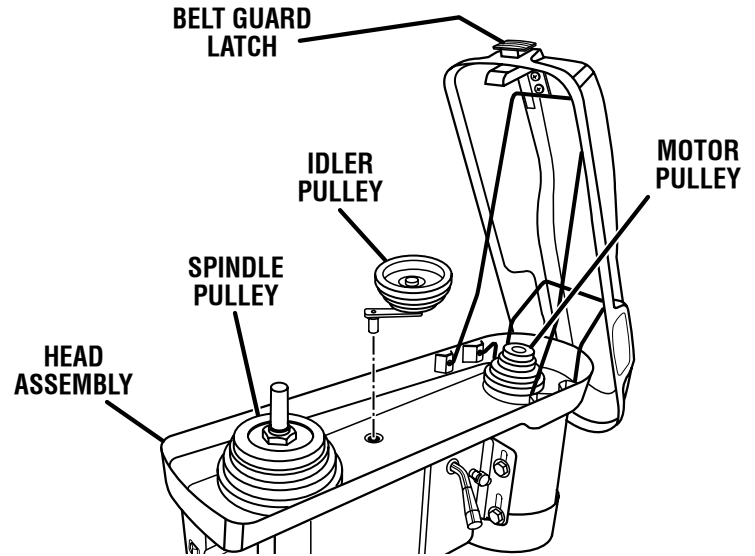

Fig. 8

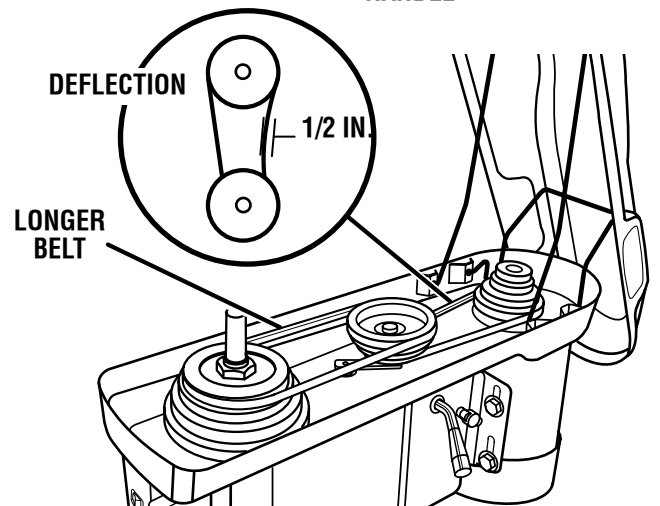
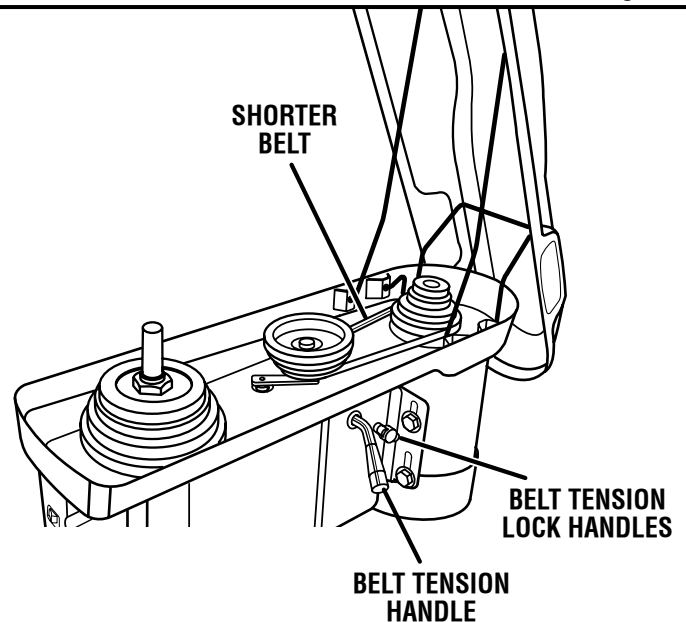

Fig. 9

ASSEMBLY

TO INSTALL THE STORAGE TRAY

See Figure 10.

- Locate the pre-assembled storage tray.
- Completely remove the screw and hex nut from one side of the storage tray assembly.
- Place the storage tray assembly around column and above collar. Securely tighten in place using screw and hex nut. Make sure the storage tray is located above the column collar. Be careful not to overtighten the hex nuts.

TO INSTALL THE FEED HANDLES

See Figure 11.

- Locate three (3) feed handles.
- Screw the feed handles into the threaded holes in the hub and tighten.
- Tighten feed handles using the open end of the hex box wrench included with drill press.

TO INSTALL THE CHUCK

See Figure 12.

- Clean the tapered surfaces on the chuck and spindle with a clean cloth. Make sure there are no foreign particles sticking to these surfaces. The slightest piece of dirt on these surfaces will prevent the chuck from seating properly. This will cause the drill to “wobble”.
- Slide chuck onto spindle of drill press.
- Push up on chuck assembly as you rotate it.
- Unlock table support lock and raise table so its about two inches below tip of chuck.
- Turn chuck sleeve clockwise and open jaws in chuck completely.
- Place a piece of wood on table. Turn feed handles counterclockwise and force chuck against table until chuck is secure.

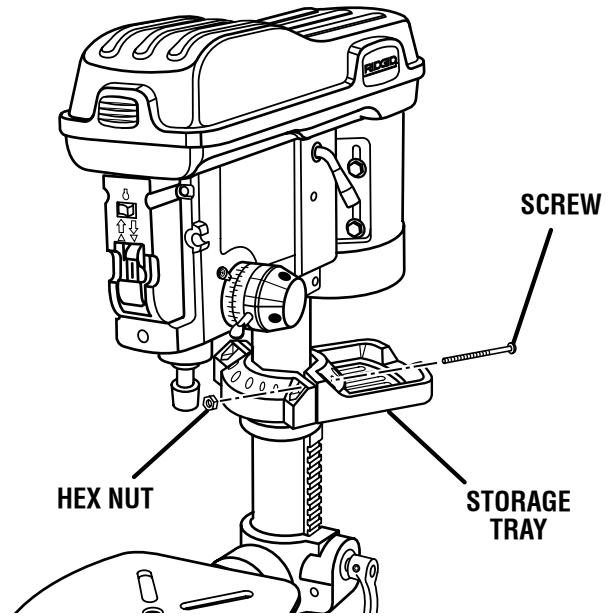

Fig. 10

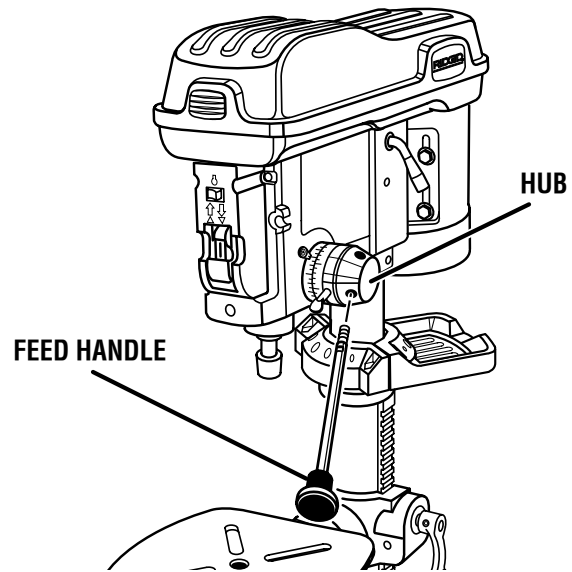

Fig. 11

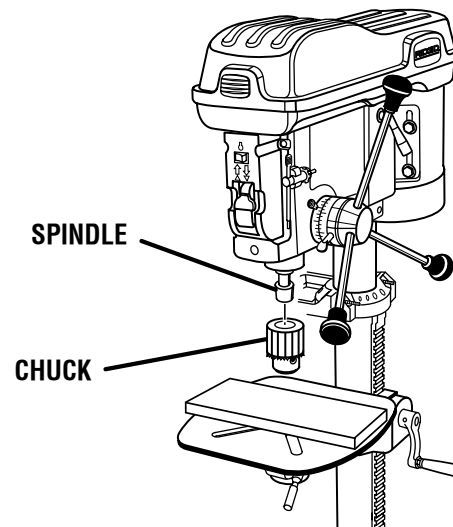

Fig. 12

ASSEMBLY

TO INSTALL THE LIGHT BULB

See Figure 13.

⚠ WARNING:

Failure to unplug drill press could result in accidental starting causing possible serious personal injury.

- Remove the amber colored lens cover by removing the two Phillips screws.
- Install a light bulb (not larger than 60 watt) into the socket inside the head.
- Replace the lens cover.

TO SQUARE THE TABLE TO HEAD

See Figure 14.

- Insert precision round steel rod or straight drill bit approximately 3 in. (76.2 mm) long into chuck and tighten.
- With table raised to working height and locked on column, place combination square flat on table beside rod or bit.
- If an adjustment is necessary, loosen the set screw under bevel lock with a 3 mm hex key, then loosen the table bevel lock bolt with the hex box wrench (included). (This adjustment is located under the table).
- Align the table square to the bit by rotating table until the square and rod or bit are in line.
- Retighten table bevel lock.
- Retighten set screw.

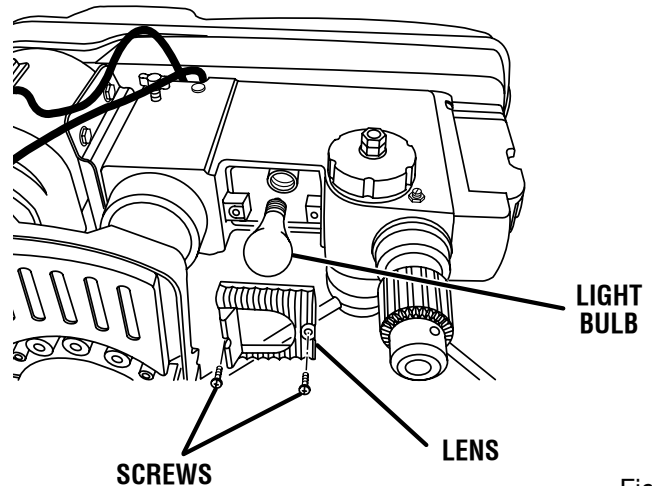

Fig. 13

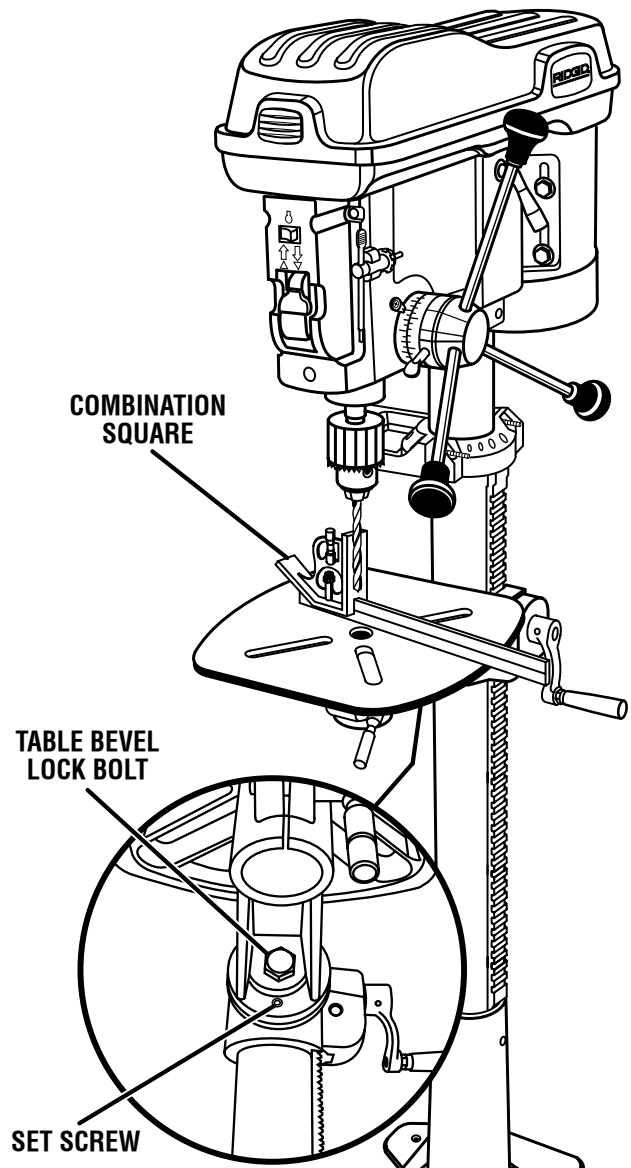

Fig. 14

OPERATION

⚠ WARNING:

Do not allow familiarity with tools to make you careless. Remember that a careless fraction of a second is sufficient to inflict severe injury.

⚠ WARNING:

Before attempting to use your drill press familiarize yourself with all operating features and safety requirements.

⚠ WARNING:

Always wear safety goggles or safety glasses with side shields during power tool operation or when blowing dust. If operation is dusty, also wear a dust mask.

TO LOCK THE SWITCH

See Figure 15.

- Place the switch in the **OFF (O)** position.
- Wait until the drill press has come to a full and complete stop.
- Remove the switch key from the switch assembly. Store key in safe place.

NOTE: In an emergency: If the drill bit binds, stalls, stops or tends to tear the workpiece loose, you can quickly turn the drill off by hitting the switch with the palm of your hand.

⚠ WARNING:

For your own safety, always push the switch OFF when drill press is not in use, remove key and keep it in a safe place, also, in the event of a power failure (all of your lights go out) or blown fuse or tripped circuit breaker, turn switch off, lock it and remove the key. This will prevent the drill press from starting up again when the power comes back on.

TO INSTALL BITS

See Figure 16.

- Unplug your drill press.
- Open or close the chuck jaws to a point where the opening is slightly larger than the drill bit you intend to use.
- Insert drill bit into chuck the full length of the jaws.

⚠ WARNING:

Do not insert drill bit into chuck jaws and tighten as shown in figure 16. This could cause drill bit to be thrown from your drill resulting in possible serious personal injury or damage to your chuck.

- Tighten chuck jaws securely using the chuck key provided. **DO NOT** use a wrench to tighten or loosen the chuck jaws.
- Remove chuck key and return to storage area.

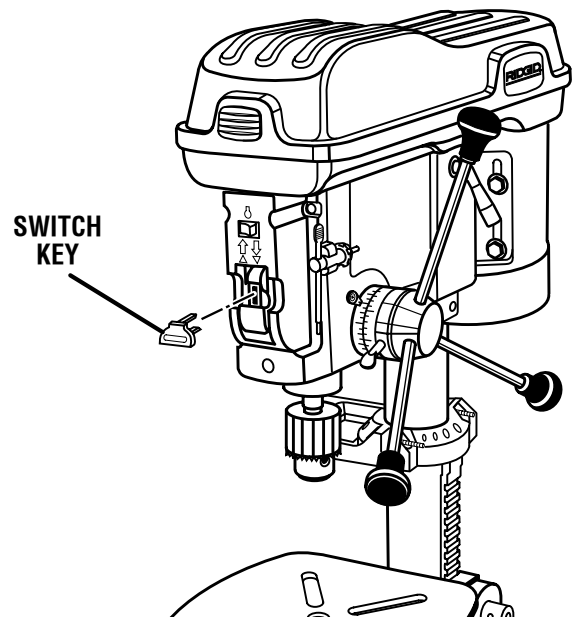

Fig. 15

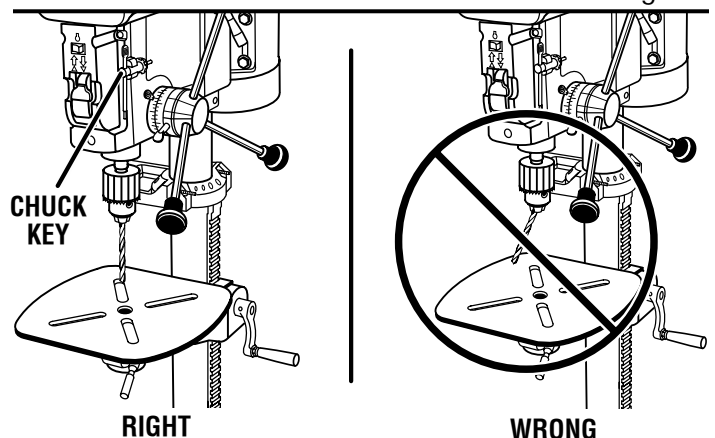

Fig. 16

OPERATION

TO POSITION TABLE AND WORKPIECE

See Figures 17 and 18.

- Lock the table to the column in a position so that the tip of the drill is just a little above the top of the workpiece.
- Always place a piece of backup material (wood, plywood, etc.) on the table underneath the workpiece. This will prevent “splintering” or making a heavy burr on the underside on the workpiece as the drill breaks through.
- To keep the backup material from spinning out of control, it must contact the left side of the column, as illustrated.

⚠ WARNING:

To prevent the workpiece or the backup material from being torn from your hand while drilling, position them against the left side of the column. If the workpiece or the backup material are not long enough to reach the column, clamp them to the table. Failure to do this could result in personal injury.

NOTE: For small pieces that cannot be clamped to the table, use a drill press vise (not included).

⚠ WARNING:

The vise must be clamped or bolted to the table to reduce the risk of injury from spinning work and vise or tool breakage.

⚠ WARNING:

Check extension cords before each use. If damaged, replace immediately. Never use tool with a damaged cord since touching the damaged area could cause electrical shock resulting in serious injury.

TO MARK HOLE LOCATION

- Make a dent in the workpiece where you want the hole, using a center punch or a sharp nail.
- Before turning the switch on, bring the drill down to the workpiece lining it up with the hole location.

TO DRILL

- Pull down on the feed handles with only enough effort to allow the drill to cut.
- Feeding too slowly might cause the drill to burn.
- Feeding too rapidly might stop the motor, cause the belt or drill to slip, tear the workpiece loose or break the drill bit.

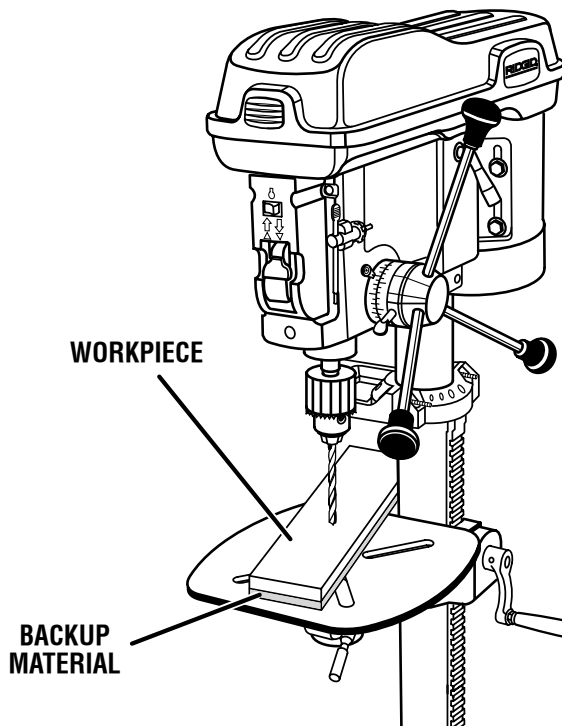

Fig. 17

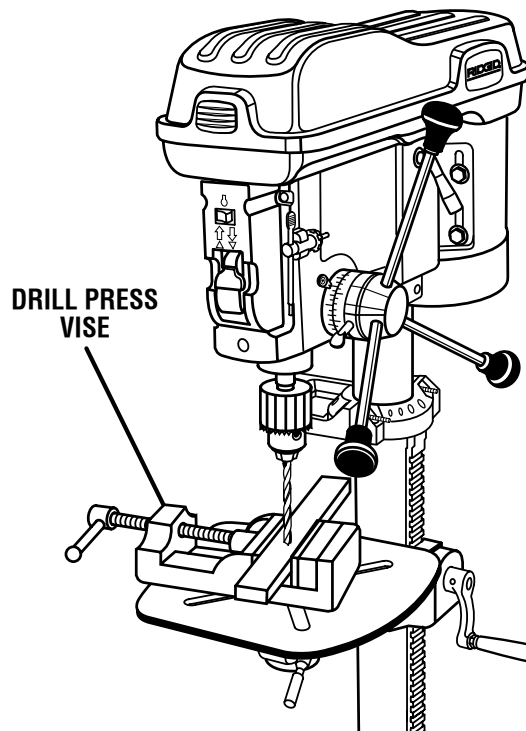

Fig. 18

OPERATION

TO DRILL TO A SPECIFIC DEPTH

See Figure 19.

To drill a blind hole (not all the way through) to a given depth, proceed as follows.

- Mark the depth of the hole on the workpiece.
- Loosen the depth scale lock.
- With the switch **OFF (O)**, bring the drill bit down until the tip of lip of the bit are even with the mark.
- Turn the depth scale counterclockwise until it stops moving.
- Tighten the depth scale lock.
- The drill bit will stop at this depth until the depth scale is readjusted.

TO DRILL USING THE DEPTH SCALE

See Figure 20.

- With the power off (O), loosen the depth scale lock.
- Place workpiece on table. Adjust table until the tip of the drill bit is just a little above the top of the workpiece, turn the depth scale counterclockwise to zero.
- Turn the depth scale clockwise until the depth scale indicator points to the desired drilling depth on the depth scale.
- Tighten the depth scale lock.
- The chuck or drill will now be stopped after traveling downward the distance selected on the depth scale.

TO LOCK CHUCK AT DESIRED DEPTH

See Figure 20.

- With the switch off (O), loosen the depth scale lock.
- Turn the feed handles until the chuck is at the desired depth. Hold feed handles at this position.
- Turn the depth scale clockwise until it stops.
- Tighten the depth scale lock.
- The chuck will now be held at this depth when the feed handles are released.

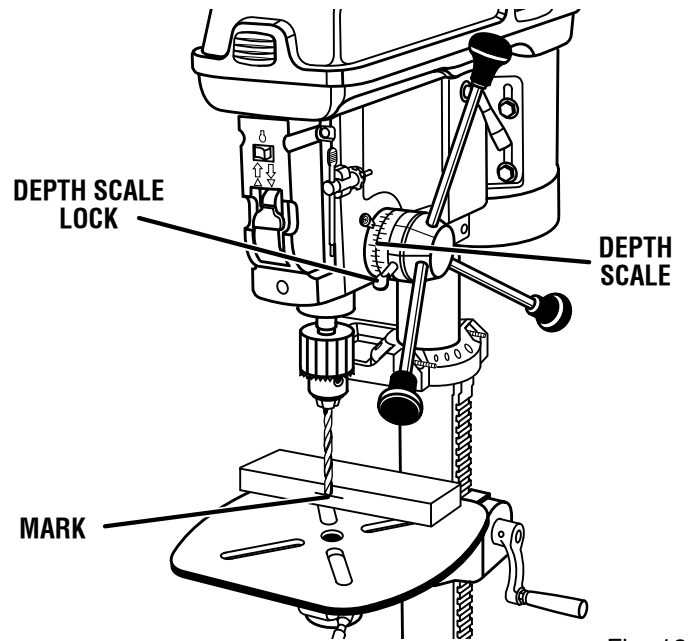

Fig. 19

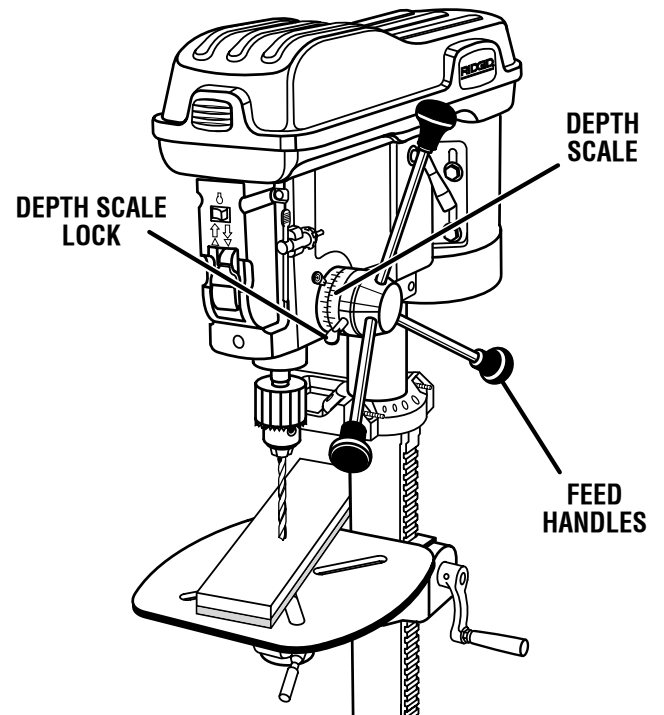

Fig. 20

OPERATION

TO TILT TABLE

See Figure 21.

To use the table in a bevel (tilted) position:

- Loosen the set screw under table bevel lock with hex key. Loosen bevel lock bolt with the hex box wrench (included).
- Tilt table to desired angle by reading bevel scale. Retighten bevel lock and set screw.

⚠ WARNING:

To reduce the risk of injury from spinning work or tool breakage, always clamp workpiece and backup material securely to table before operating drill press with the table tilted.

To return table to original position:

- Loosen set screw and bevel lock, tilt table back to 0° on bevel scale and retighten set screw, then tighten bevel lock.

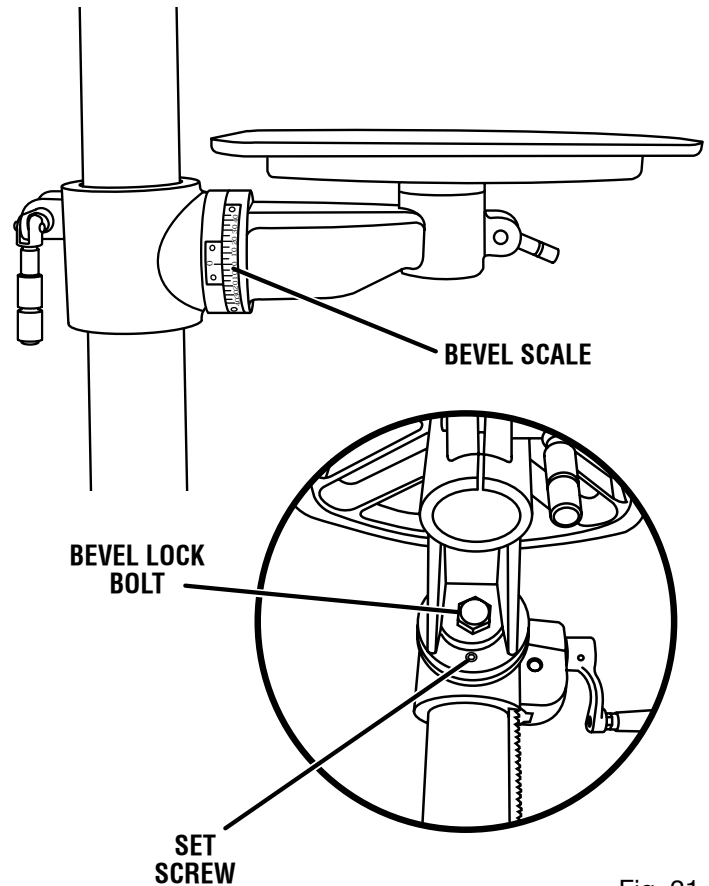

Fig. 21

ADJUSTMENTS

⚠ WARNING:

Before performing any adjustment, make sure the drill press is unplugged from the power supply and the switch is in the OFF position. Failure to heed this warning could result in serious personal injury.

TO ADJUST TABLE HEIGHT

See Figure 22.

- Hold the table with one hand then loosen the table support lock handle.
- To raise the table, turn the table adjustment handle clockwise.
- To lower the table, turn the table adjustment handle counterclockwise.
- Once the table is in the desired position, retighten the table support lock handle.

TO CHANGE SPEEDS

The spindle speed is determined by the location of the belts on the pulleys inside the head assembly. The speed chart located on the inside of the belt guard shows the recommended speed and pulley configuration for each drilling operation:

- Loosen the two belt tension screws located on each side of the head assembly.
- Push the belt tension lever to release belt tension and to loosen the belts.
- Open the head assembly cover and reposition the belt according to the speed chart. Close the cover.
- Push the belt tension lever firmly back into position assuring drive belt is tight. While holding tension on the motor, retighten the two belt tension knobs securely.

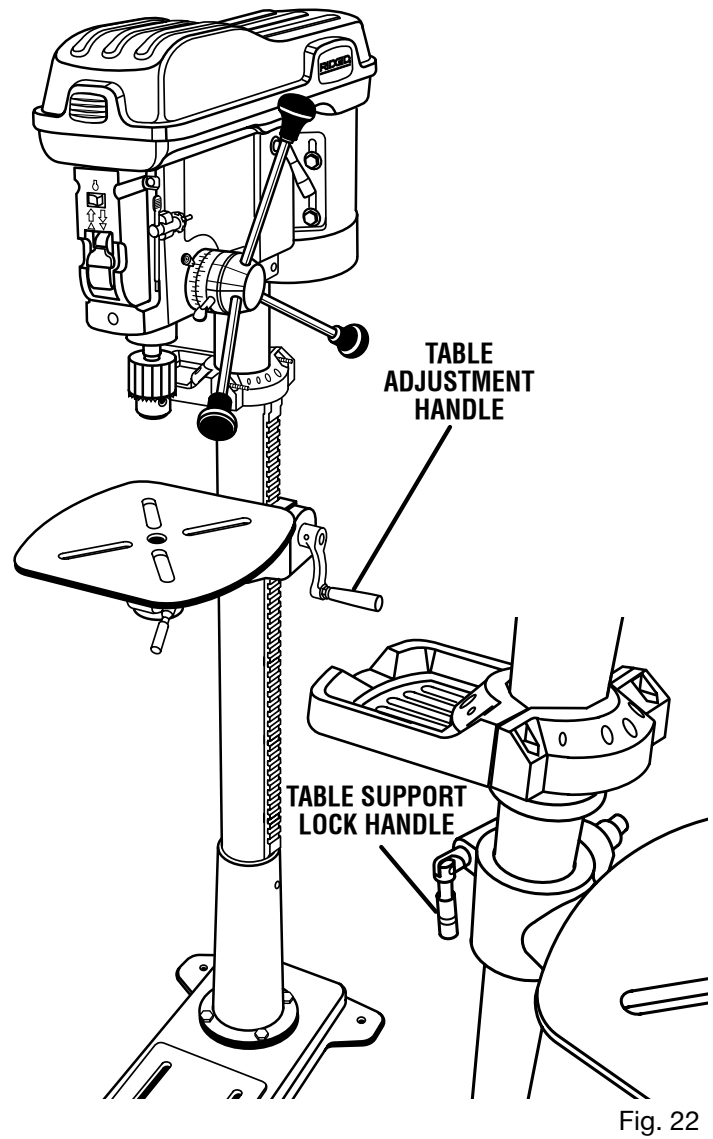

Fig. 22

ADJUSTMENTS

TO CONVERT FROM RIGHT HAND OPERATION TO LEFT HAND OPERATION

See Figures 23 - 27.

The drill press is shipped from the factory with feed handles set-up for right hand operation. However, if desired, the drill press feed handles can be converted to left hand operation.

WARNING:

For your own safety turn switch OFF and remove plug from power source outlet before making any adjustments.

- To help keep the drill chuck from falling on to the floor, place a piece of scrap wood on top of the table and raise the table until it engages the chuck.

CAUTION:

Releasing the spring assembly without proper support of the chuck will allow the quill assembly to drop on top of the drill press table.

- Firmly hold spring housing against head so it remains engaged with the 4 mm cap screw. Remove both nuts and washer from the feed handle assembly shaft. See Figure 23.
- Use both hands to firmly grasp the spring housing. Pull the spring housing slightly away from the drill press, disengaging the spring housing from the cap screw. While firmly holding the housing, allow the spring assembly to unwind inside housing clockwise until the spring tension is relieved.

CAUTION:

To prevent injury, be careful not to allow the spring assembly to rapidly unwind.

- Remove the spring housing.
- Slide the feed handle assembly out from the right side of the head. See Figure 24.
- Remove the bushing located on the left of the head assembly as shown. It may be necessary to tap this bushing out from the right side. Reinstall this bushing on the right side of the drill press.
- Remove the 4 mm socket head cap screw from the left side of the drill press and install in the same position on the right side of the drill press. Tighten screw.

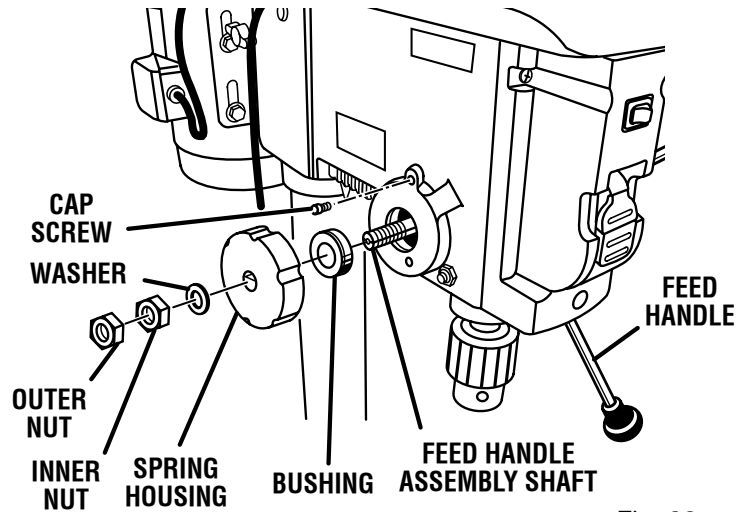

Fig. 23

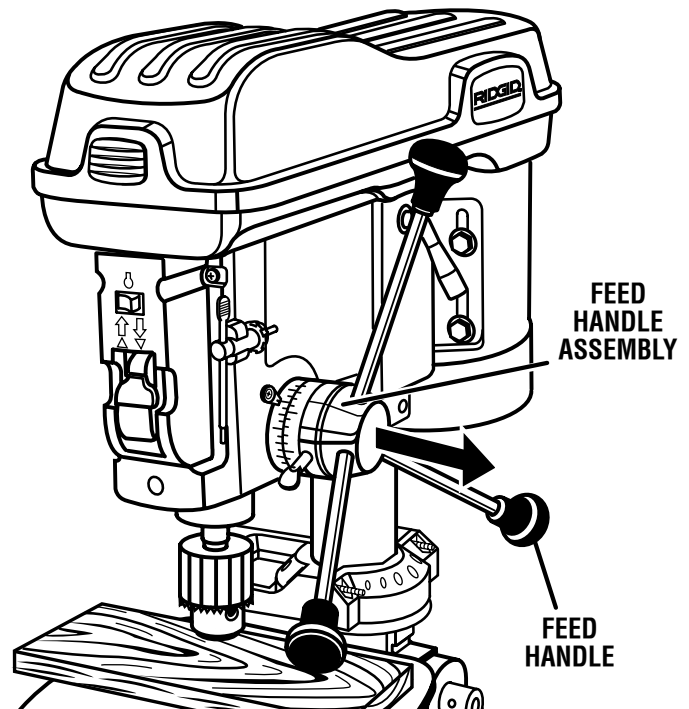

Fig. 24

ADJUSTMENTS

- Remove the stop pin screw from the right side of the drill press and install in the left side of the drill press as shown. Tighten stop pin screw. *See Figure 25.*
- Install the feed handle assembly and depth stop ring on the left side of the drill press. With the chuck at its highest possible position, turn the depth scale clockwise until it stops and tighten the depth scale lock. This will prevent the quill from dropping while installing the spring. *See Figures 25 - 26.*
- Install the spring housing on the right side of the drill press, making sure the two housing screw heads face outwards. The center tab of the spring must go in the slot on the feed handle assembly. *See Figure 27.*
If necessary, use a screwdriver to align and keep spring centered during installation.
- Replace washer and screw the outer and inner nuts back on the feed handle assembly as shown in figure 27. Hold the spring assembly in place and loosely assemble both nuts. See following page for quill return spring adjustment.
- Remove the depth scale and reposition so numbers are legible as shown. *See Figure 26.*
- Remove the depth scale indicator from the right side of the drill press and reinstall on the left side of the drill press.
- Remove the scrap wood from the table top.

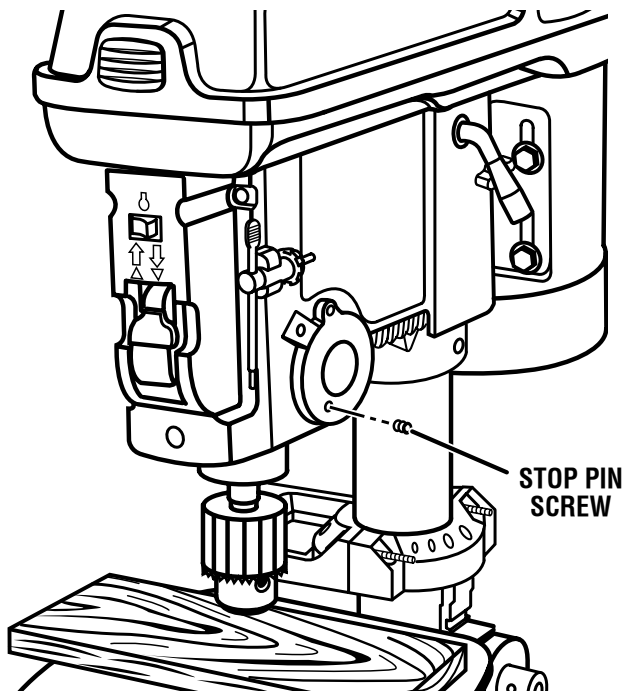

Fig. 25

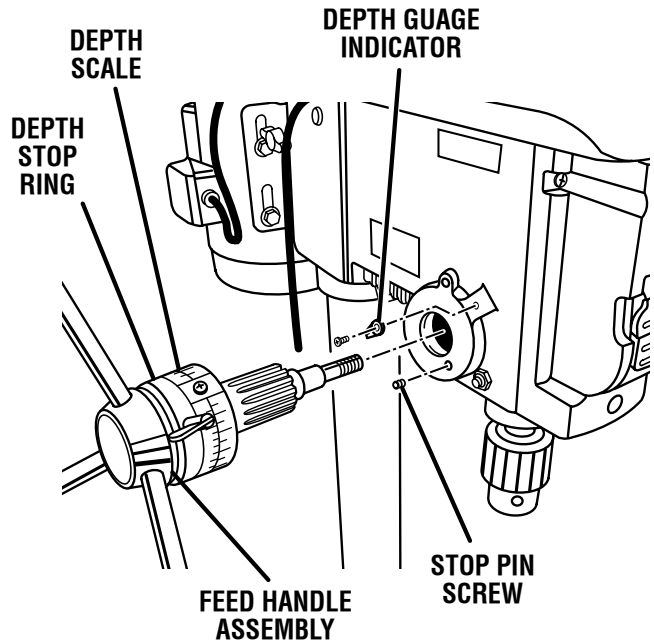

Fig. 26

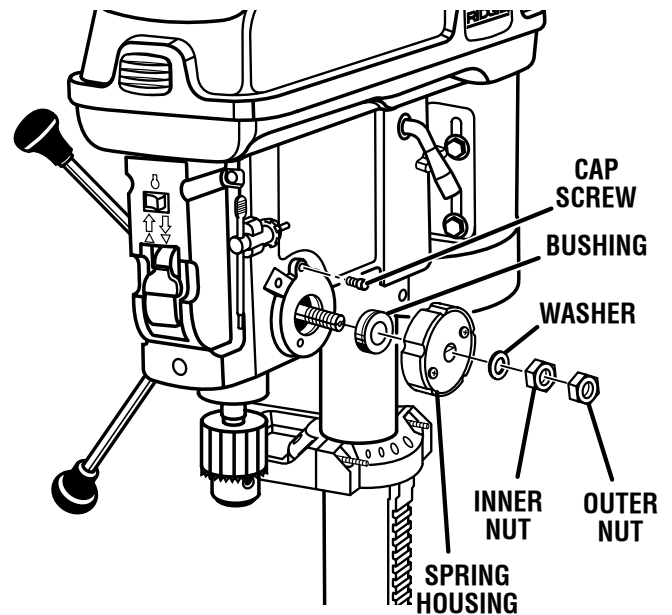

Fig. 27

ADJUSTMENTS

⚠ WARNING:

For your own safety turn switch OFF and remove plug from power source outlet before making any adjustments. To reduce the risk of injury from thrown parts due to spring release, follow instructions carefully and wear eye goggles.

TO ADJUST QUILL RETURN SPRING

See Figure 28.

NOTE: The return spring tension is set at the factory and should not require further adjustment.

IMPORTANT: If you switched your drill press from right hand operation to left hand operation, follow the procedure below to adjust spring tension.

- With the chuck at its highest possible position, turn the depth scale clockwise until it stops and tighten the depth scale lock. This will prevent the quill from dropping while tensioning the spring.

NOTE: For right hand operation (feed handle on right side) turn the depth scale counterclockwise until it stops and tighten the depth scale lock.

- Check to make sure spring housing is mounted correctly. When spring housing is placed on the right side (feed handles mounted on left side), the housing screws face out as shown.
- Lower table for additional clearance.
- Firmly hold the spring assembly against the head keeping it engaged with the cap screw while loosening and removing the outer nut only.
- Loosen inner nut (approximately 1/4 in. [6.4 mm]) and disengage spring housing from the cap screw. Using both hands turn spring housing clockwise to the next notch and engage with the cap screw.

NOTE: For right hand operation (feed handle on right side) turn spring counterclockwise to the next notch and engage with the cap screw.

- Finger tighten inner nut against spring housing. Do not overtighten as this will restrict quill movement.
- Loosen depth scale lock and check quill return by rotating feed handles, lowering quill.
- Proper tension is achieved when quill returns gently to full up position when released from 3/4 in. (19 mm) depth.

- If there is not enough tension on spring, repeat steps
- moving only one notch each time and checking tension after each repetition.
- After adjusting spring, replace outer nut and tighten to inner nut. But do not overtighten against inner nut.
- Check quill movement to make sure it is smooth and unrestricted. If movement is too tight, loosen outer nut and slightly loosen inner nut until unrestricted. Retighten outer nut.

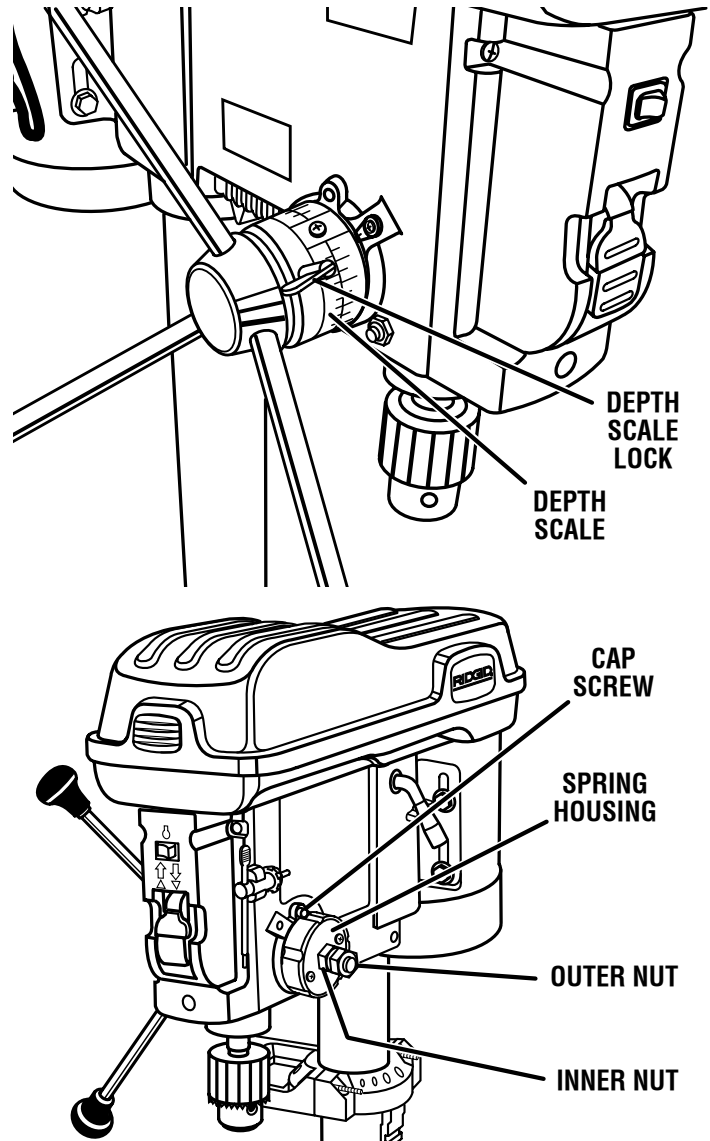

Fig. 28

ADJUSTMENTS

TO ADJUST THE BELT LATCH GUARD

See Figure 29.

The button latch is adjusted at the factory to be self latching when the pulley guard lid is closed.

If adjustment is needed.

- Loosen the two screws securing the latch to the lid and move latch back until the lid closes without depressing the button.
- The button can also be adjusted up and down to assure lid closes tight by loosening the two screws in back of the latch button, and moving the button up or down as needed.

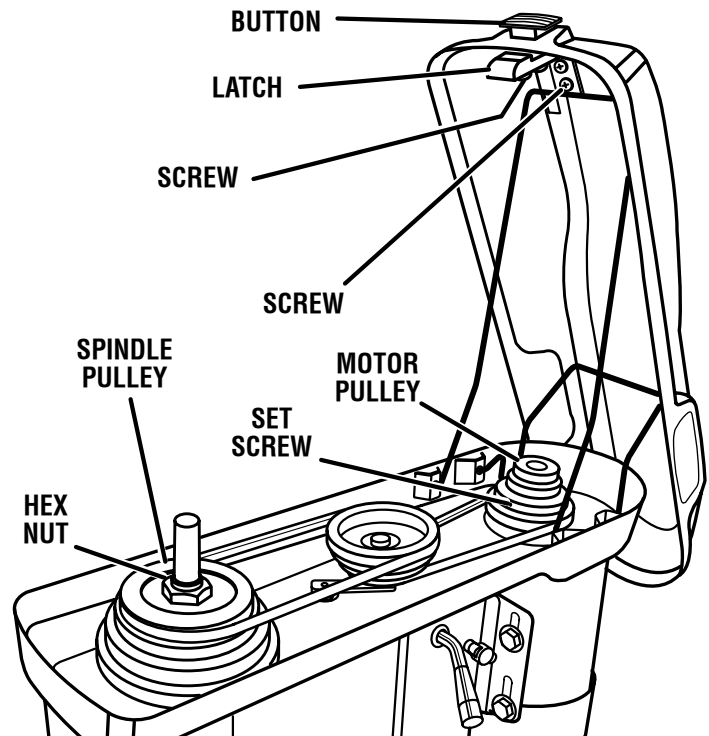

Fig. 29

MAINTENANCE

WARNING:

When servicing use only identical RIDGID replacement parts. Use of any other parts may create a hazard or cause product damage.

GENERAL MAINTENANCE

After using your drill press, clean it completely and lubricate all sliding and moving parts. Apply a light coat of automotive type paste wax to the table and column to help keep the surfaces clean.

CAUTION:

Do not at any time let brake fluids, gasoline, petroleum-based products, penetrating oils, etc. come in contact with plastic parts. They contain chemicals that can damage, weaken or destroy plastic.

HEAD ASSEMBLY

Frequently blow out any saw dust that may accumulate inside the motor housing.

PULLEYS

See Figure 29.

Should you feel an unusually high level of vibration, the pulleys may not be tightly secured on the motor and/or spindle shafts. To make sure the pulleys are properly seated and tight, locate the set screw on the motor pulley and the hex nut on the spindle pulley as shown in figure 30. Tighten the set screw with a hex wrench and the hex nut with an adjustable wrench.

NOTE: Turn hex nut counterclockwise to tighten.

REMOVING CHUCK

See Figure 30.

- Unplug the drill press.
- Open jaws of chuck as wide as they will go by turning chuck sleeve.
- Using a downwards motion carefully tap on the chuck with a mallet while slowly turning the chuck with your other hand.
- Remove the chuck from the drill press spindle.

IMPORTANT: Make sure and hold onto the chuck to prevent it from dropping when it is released from the spindle nose.

NOTE: If chuck is difficult to remove, place dowel rod on top surface of chuck and tap dowel with hammer.

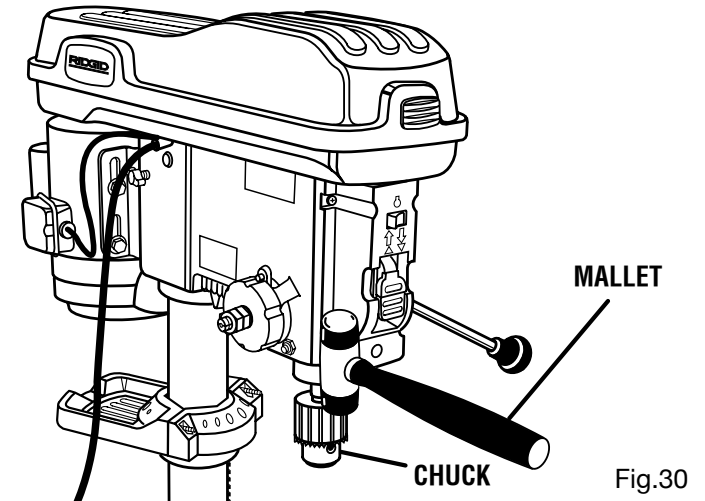

LUBRICATION

The ball bearings in the quill and V-belt pulley are permanently lubricated. To lubricate the spindle, pull quill down to maximum depth and oil moderately once every three months. Oil all slide bars lightly every two months. If cranking becomes difficult, grease bracket lightly. Periodically lubricate the gear rack in order to keep the vertical movement smooth and to help prolong the life of your drill press.

WARNING:

Always wear safety goggles or safety glasses with side shields during power tool operation or when blowing dust. If operation is dusty, also wear a dust mask.

WARNING:

To ensure safety and reliability, all repairs with the exception of the externally accessible brushes should be performed by a RIDGID Authorized Service Center.

ACCESSORIES

Use Only Accessories Designed For This Drill Press To Reduce the Risk of Serious Injury From Thrown Broken Parts Or Work Pieces

■ When cutting large diameter holes:

Clamp the workpiece firmly to the table. Otherwise the cutting may grab and spin it at high speed.

Use only one piece, cup-type, hole cutters.

Do not use fly cutters or multi-part hole cutters as they can come apart or become unbalanced in use.

Keep speed below 1500/min..

- Drum sanders must never be operated on this drill press at a speed greater than 1800/min..
- Do not install or use any drill that exceeds 7 in. (178 mm) in length or extends 6 in. (152 mm) below the chuck jaws. They can suddenly bend outward or break.
- Do not use wire wheels, router bits, shaper cutters, circle (fly) cutters or rotary planers on this drill press.

TROUBLESHOOTING

PROBLEM	CAUSE	SOLUTION
Noisy Operation	<ol style="list-style-type: none"> 1. Incorrect belt tension. 2. Dry spindle. 3. Loose spindle pulley 4. Loose motor pulley 	<ol style="list-style-type: none"> 1. Adjust tension. See “Assembly - To Install Idler Pulley” section. 2. Lubricate spindle. See “Maintenance” section. 3. Checking tightness of retaining nut on pulley, and tighten if necessary. 4. Tighten set screws in pulleys.
Drill bit burns	<ol style="list-style-type: none"> 1. Incorrect speed 2. Chips not coming out of hole 3. Dull drill bit 4. Feeding too slow 5. Not lubricated 	<ol style="list-style-type: none"> 1. Change speed. See “Adjustment” section. 2. Retract drill bit frequently to clear hole chips 3. Resharpen or replace drill bit 4. Feed fast enough, allow drill bit to cut 5. Lubricate drill bit. See “Operation” section.
Drill bit leads off, hole not round	<ol style="list-style-type: none"> 1. Hard grain in wood or lengths of cutting lips and/or angles not equal. 2. Bent drill bit 	<ol style="list-style-type: none"> 1. Resharpen drill bit correctly or replace. 2. Replace drill bit
Wood splinters on underside	<ol style="list-style-type: none"> 1. No “backup material” under workpiece 	<ol style="list-style-type: none"> 1. Use “backup material”. See “Operation” section.
Workpiece torn loose from hand	<ol style="list-style-type: none"> 1. Not supported or clamped properly 	<ol style="list-style-type: none"> 1. Support or clamp workpiece. See “Operation” section.
Drill bit binds in workpiece	<ol style="list-style-type: none"> 1. ‘Workpiece pinching drill bit or excessive feed pressure. 2. Improper belt tension 	<ol style="list-style-type: none"> 1. Support or clamp workpiece. See “Operation” section. 2. Adjust tension. See “Assembly - To Install Idler Pulley” section.
Excessive drill bit runout or wobble.	<ol style="list-style-type: none"> 1. Bend drill bit 2. Worn spindle bearings 3. Drill bit not properly installed in chuck 4. Chuck not properly installed 	<ol style="list-style-type: none"> 1. Use a straight drill bit. 2. Replace bearings 3. Install drill bit properly. See “Operation” section. 4. Install chuck properly, refer to “Assembly-To Install the Chuck”.
Quill returns too slow or too fast	<ol style="list-style-type: none"> 1. Spring has improper tension 	<ol style="list-style-type: none"> 1. Adjust spring tension. See “Adjustments - To Adjust Quill Return Spring” section.
Chuck will not stay attached to spindle, it falls off when trying to install.	<ol style="list-style-type: none"> 1. Dirt, grease or oil on the tapered inside surface of chuck or on the spindles tapered surface. 	<ol style="list-style-type: none"> 1. Using a household detergent, clean the tapered surface of the chuck and spindle to remove all dirt, grease and oil.
Chuck rotates but does not deliver sufficient torque to properly drill.	<ol style="list-style-type: none"> 1. Spindle pulley nut (part no. 821742) loose. 	<ol style="list-style-type: none"> 1. Turn nut counterclockwise to tighten. (The nut has left-hand threads.)

WARRANTY

RIDGID® HAND HELD AND STATIONARY POWER TOOL LIMITED THREE YEAR WARRANTY AND 90-DAY SATISFACTION GUARANTEE POLICY

This product is manufactured by One World Technologies, Inc., under a trademark license from RIDGID, Inc. All warranty communications should be directed to One World Technologies, Inc., attn: RIDGID handheld and stationary power tool technical service at (toll free) 1-866-539-1710.

90-DAY SATISFACTION GUARANTEE POLICY

During the first 90 days after the date of purchase, if you are dissatisfied with the performance of this RIDGID tool for any reason you may return the tool to the dealer from which it was purchased for a full refund or exchange. To receive a replacement tool you must present proof of purchase and return all original equipment packaged with the original product. The replacement tool will be covered by the limited warranty for the balance of the three year warranty period.

WHAT IS COVERED UNDER THE LIMITED THREE YEAR WARRANTY

This warranty covers all defects in workmanship or materials in this RIDGID tool for the three year period from the date of purchase. This warranty is specific to this tool. Warranties for other RIDGID products may vary.

HOW TO OBTAIN SERVICE

To obtain service for this RIDGID tool you must return it, freight prepaid, to an authorized RIDGID service center for hand held and stationary power tools. You may obtain the location of the authorized service center nearest you by calling (toll free) 1-866-539-1710 or by logging on to the RIDGID website at www.ridgid.com. When requesting warranty service, you must present the proof of purchase documentation, which includes a date of purchase. The authorized service center will repair any faulty workmanship, and either repair or replace any defective part, at our option at no charge to you.

WHAT IS NOT COVERED

This warranty applies only to the original purchaser at retail and may not be transferred. This warranty only covers defects arising under normal usage and does not cover any malfunction, failure or defect resulting from misuse, abuse, neglect, alteration, modification or repair by other than an authorized service center for RIDGID branded hand held and stationary power tools. **RIDGID, INC. AND ONE WORLD TECHNOLOGIES, INC. MAKE NO WARRANTIES, REPRESENTATIONS OR PROMISES AS TO THE QUALITY OR PERFORMANCE OF ITS POWER TOOLS OTHER THAN THOSE SPECIFICALLY STATED IN THIS WARRANTY.**

ADDITIONAL LIMITATIONS

To the extent permitted by applicable law, all implied warranties, including warranties of MERCHANTABILITY or FITNESS FOR A PARTICULAR PURPOSE, are disclaimed. Any implied warranties, including warranties of merchantability or fitness for a particular purpose, that cannot be disclaimed under state law are limited to three years from the date of purchase. One World Technologies, Inc. is not responsible for direct, indirect, incidental or consequential damages. Some states do not allow limitations on how long an implied warranty lasts and/or do not allow the exclusion or limitation of incidental or consequential damages, so the above limitations may not apply to you. This warranty gives you specific legal rights, and you may also have other rights which vary from state to state.

One World Technologies, Inc.
Hwy. 8
Pickens, SC 29671

OPERATOR'S MANUAL

15 in. DRILL PRESS

DP15501

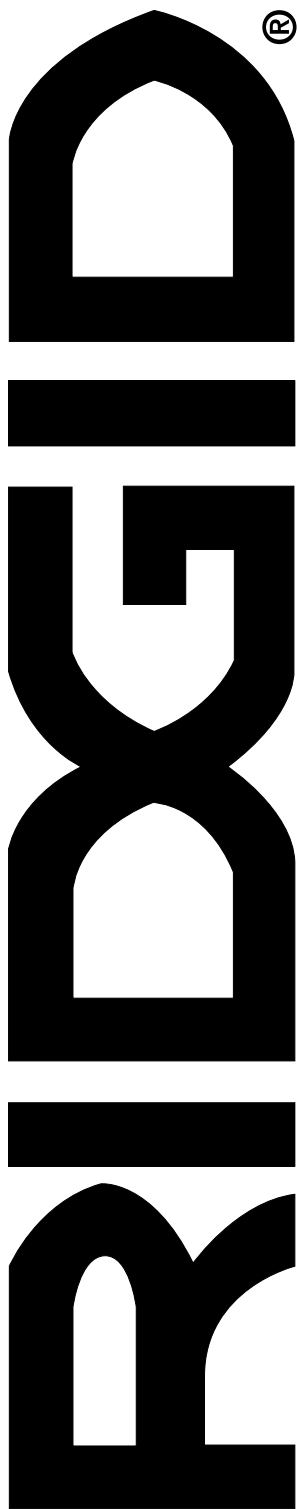

CUSTOMER SERVICE INFORMATION

For parts or service, contact your nearest RIDGID authorized service center. Be sure to provide all relevant information when you call or visit. For the location of the authorized service center nearest you, please call 1-866-539-1710 or visit us online at www.ridgid.com.

The model number of this tool is found on a plate attached to the motor housing. Please record the serial number in the space provided below. When ordering repair parts, always give the following information:

Model No. DP15501

Serial No. _____